

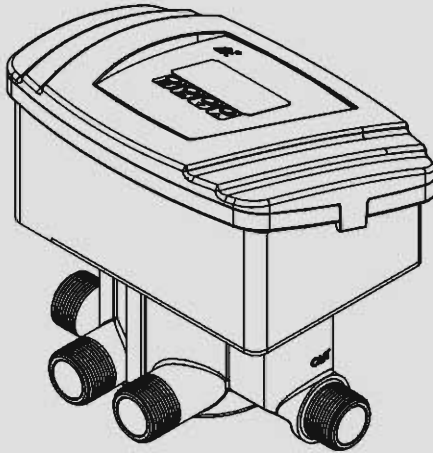

# Multi-functional Flow Control Valve for Deaerator Water Treatment Systems

Model:13504



## Instruction Manual



Please read this manual in details  
before using this valve and keep it properly  
in order to consult in the future

0WRX.466.504

## MODEL: 13504

Before the valve put into use, please fill in the below content so as to help us to refer in the future.

### **Deaerator System Configuration**

Tank Size: Dia. \_\_\_\_\_ mm, Height \_\_\_\_\_ mm;

Spongy Iron Model \_\_\_\_\_, Weight \_\_\_\_\_ Kg;

Control Valve Model \_\_\_\_\_ ; Number \_\_\_\_\_ ;

Pressure of Inlet Water \_\_\_\_\_ MPa;

Hardness of Raw Water \_\_\_\_\_ mmol/L.

### Parameter Set

Service Time \_\_\_\_\_ Min.;

Left Chamber Backwash Time \_\_\_\_\_ Min.;

Right Chamber Backwash Time \_\_\_\_\_ Min.;

Fast Rinse Time \_\_\_\_\_ Min.

### Factory Default:

Service Time \_\_\_\_\_ 1 \_\_\_\_\_ Day;

Left Chamber Backwash Time \_\_\_\_\_ 20 \_\_\_\_\_ Min.;

Right Chamber Backwash Time \_\_\_\_\_ 20 \_\_\_\_\_ Min.;

Fast Rinse Time \_\_\_\_\_ 20 \_\_\_\_\_ Min.

# Catalogue

Notice.....	3
1. Product Overview.....	4
1.1. Main Application & Applicability.....	4
1.2. Product Characteristics.....	4
1.3. Service Condition.....	5
1.4. Product Structure and Technical Parameters.....	6
1.5. Installation.....	7
2. Basic Setting & Usage.....	9
2.1. The Function of PC Board.....	9
2.2. Basic Setting & Usage.....	10
3. Application.....	13
3.1. Flow Chart.....	13
3.2. The Function and Connection of PC Board.....	15
A. Signal Output.....	15
B. Interlock.....	16
C. Backwash Pump Booster Connector.....	17
D. Remote Handling Connector.....	17
3.3. System Configuration and Flow Rate Curve.....	18
3.4. Parameter Enquiry and Setting.....	19
3.5. Trial Running.....	23
3.6. Trouble-Shooting.....	24
3.7. Spare Part and Part No. ....	26
4. Warranty Card.....	28

## Notice

- To ensure normal operation of the valve, please consult with professional installation or repairing personnel before use it.
- If there are any of pipeline engineering and electric works, there must be finished by professional at the time of installation.
- Do not use the control valve with the water that is unsafe or unknown quality.
- Do not put the valve near the hot resource, high humidity, corrosive, intense magnetic field or intense vibrations environment. And do not leave it outside.
- Forbidden to use the valve connectors as support to carry the system.
- Please use this product under the water temperature between 5 ~ 50°C, water pressure 0.15 ~ 0.6MPa. Failure to use this product under such conditions voids the warranty.
- If the water pressure exceeds 0.6Mpa, a pressure reducing valve must be installed in the water inlet. While, if the water pressure under 0.15MPa, a booster pump must be installed in the water inlet.
- Do not let children touch or play, because carelessness operating may cause the procedure changed.
- When the attached cables of this product and transformer are changed, they must be changed to the one that is from our factory.

# 1. Product Overview

## 1.1. Main Application & Applicability

Used for deoxidating for steam boiler water treatment systems.

Be suitable for double-chamber ambient temperature spongy iron deaerator.

## 1.2. Product Characteristics

### ➤ Simple structure and reliable sealing

It adopts hermetic head faces with high degree pottery and corrosion resistance for opening and closing. It combines with Service, Left Chamber Backwash, Right Chamber Backwash and Fast Rinse.

### ➤ Manual function

Realize regeneration immediately by pushing manual button at any time.

### ➤ Long outage indicator

If outage overrides 3 days, the time of day indicator “12: 12” will flash to remind people to reset new time of day. The other set parameters do not need to reset. The process will continue to work after power on.

### ➤ LED dynamic screen display

The stripe on dynamic screen flash, it indicates the control valve is in service, otherwise, it is in regeneration cycle.

### ➤ Buttons lock

No operations to buttons on the controller within 1 minute, button lock indicator light on which represent buttons are locked. Before operation press and hold the ▲ and ▼ buttons for 5 seconds to unlock. This function can avoid incorrect operation.

### ➤ Interlock function

It has a function of interlock to realize only one valve in regeneration but the other valves are in service while several valves parallel in system. In multi-steps treatment systems such as RO pre-treatment, when several valves are in series, there is only one valve in regeneration or washing to ensure pass water all the times while different valves in regeneration or washing. (Application refer to Figure 3)

### ➤ Service mode option

There are three kinds of regeneration modes optional, by days, by hours or by time of day. The time of day can be set two or three or four times of day to initiate backwash.

### ➤ Signal output

There is a signal output connector on main control board. It is for controlling external wiring ( Refer to Figure 1 and Figure 2).

There are two kinds of output modes: b-01 Mode: Turn on start of regeneration and shut

## MODEL: 13504

off end of regeneration; b-02 Mode: In service and fast rinse status, booster pump relay has signal to open, but backwash pump reply doesn't have, so it is in closed status; In left chamber backwash and right chamber backwash status, booster pump reply doesn't have signal, so it is in closed status, but backwash pump reply has signal to open.

### ➤ Remote handling input

This connector can receive external signal, used together with PLC, computer and etc. to control the valve. (Application refer to Figure 6)

### ➤ Backwash water option

Deoxidized water or raw water for backwash could be switched in program. (The wiring is refer to Figure 4 and 5)

Backwash pump reply working modes: In service and fast rinse status, it has no signal, so it is in closed statuses; In left chamber backwash and right chamber backwash status, it has signal to open.

In service and fast rinse status, electronic ball valve A open, B close; In left chamber backwash and right chamber backwash status, A close, B open.

## 1.3. Service Condition

Runxin Valve for deaerator should be used under the below conditions:

Items		Requirement
Working conditions	Water pressure	0.15MPa~0.6MPa
	Water temperature	5°C~50°C
Working environment	Environment temperature	5°C~50°C
	Relative humidity	≤95% ( 25°C )
	Electrical facility	AC100~240V/50~60Hz
Inlet water quality	Water hardness	<0.03mmol/L
	COD <sub>mn</sub>	<15mg/L ( O <sub>2</sub> )

# MODEL: 13504

## 1.4. Product Structure and Technical Parameters

A.Product dimension (The appearance is just for reference. It is subjected to the real product.)

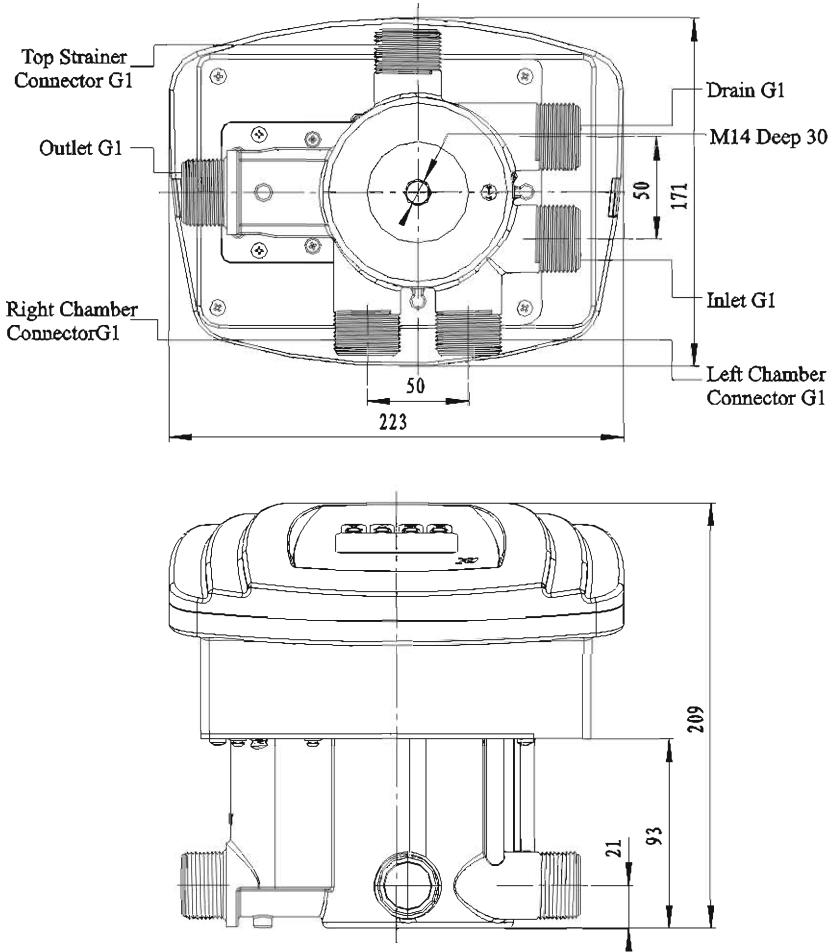

### B. Parameter

Transformer output: DC12V, 2A

Model	Inlet/ Outlet	Drain Outlet	Top Strainer Connector	Left and Right Chamber Connector	Flow Rate m <sup>3</sup> /h	Deaerator Size (in)	Remark
13504	1" M	1" M	1" M	1" M	3.5	10" ~ 18"	Remove dissolved oxygen

Remark: M—Male Thread F—Female Thread OD—Outer Diameter

### 1.5. Installation

#### A. Installation notice

Before installation, read all those instructions completely. Then obtain all materials and tools needed for installation.

The installation of product, pipes and circuits, should be accomplished by professional to ensure the product can operate normally.

Perform installation according to the relative pipeline regulations and the specification of Inlet, Outlet, Drain, Top Strainer Connector, Left Chamber Connector and Right Chamber Connector.

#### B. Device location

- ① The deaerator should be located close to drain.
- ② Ensure the unit is installed in enough space for operating and maintenance.
- ③ The unit should be kept away the heater, and not be exposed outdoor. Sunshine or rain will cause the system damage.
- ④ Please avoid to install the system in one Magnetic or strong vibration circumstance, because above factors will cause the system disorder.
- ⑤ Do not install the unit, drain pipeline in circumstance which temperature may drop below 5°C, or above 50°C.
- ⑥ One place is recommended to install the system which cause the minimum loss in case of water leaking.

#### C. Pipeline installation

The pipeline installation is like Figure 1-1 shows.

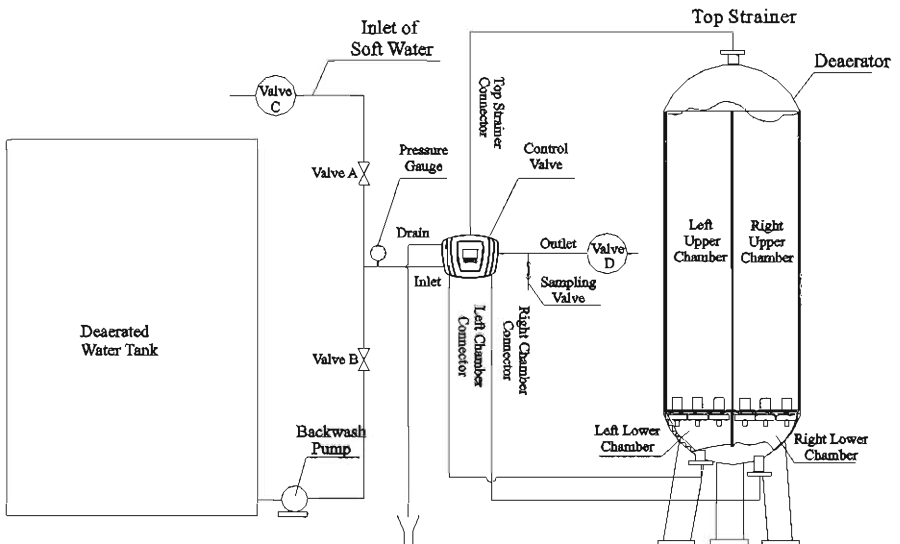

Figure 1-1



## MODEL: 13504

### ① Inlet pipeline installation.

a. As Figure 1-1 shows, install a pressure gauge in water inlet.

b. Install electronic ball valve A and manual valve C in inlet of soft water.

c. Install electronic ball valve B in inlet of deaerated water. And install backwash pump.

### ② Outlet pipeline installation.

As Figure 1-1 shows, install a sampling valve and manual valve D in outlet.

### ③ Left chamber, right chamber and top strainer pipeline installation.

As Figure 1-1 shows, install valves' relative connectors with left chamber, right chamber and top strainer of deaerator.

### ④ Drain pipeline installation.

Use UPVC or other rigid tube connect with drain outlet.



Figure 1-2 Correct Way of Drainage

### Note:

- Ensure each of pipeline parallel or vertical and support pipeline with fixed holder.
- If making a soldered cooper installation, do all sweat soldering before connecting popes to the valve. Torch heat will damage plastic parts.
- When turning threaded pipe fitting onto plastic fitting, use care not to cross thread or broken valve.
- Control valve should be higher than drain outlet, and be better not far from the drain hose.
- Be sure not connect drain with sewer, and leave a certain space between them, avoid wastewater being absorbed to the water treatment equipment, such as showed in the Figure 1-2.

## 2. Basic Setting & Usage

### 2.1. The Function of PC Board

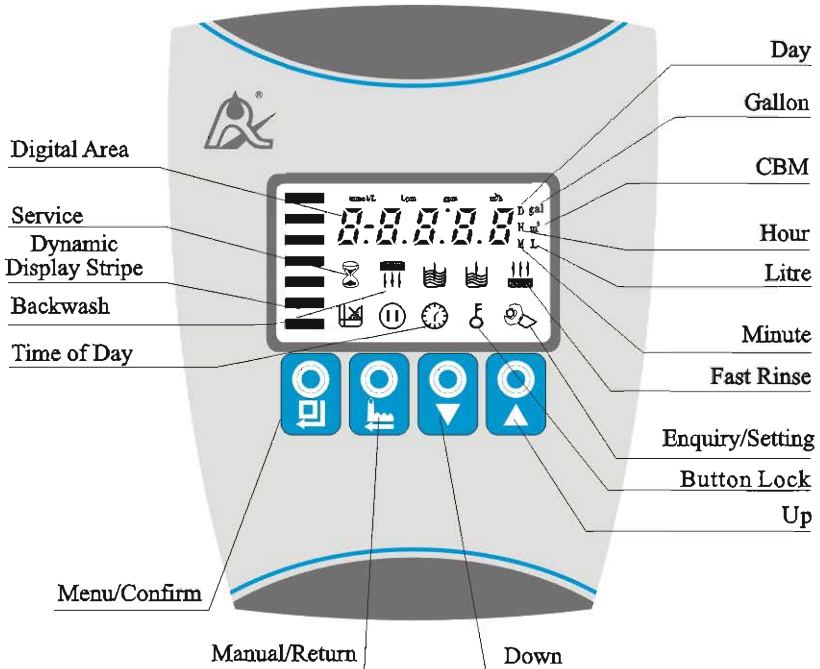

#### A. 🕒 Time of day indicator

- 🕒 Light on, display the time of day.
- When “12:12” light flash, remind you to reset the time of day if electrical service interrupted 3 days more. (If electrical service interrupted within 3 days, it doesn't need to reset the time.)









#### B. 🔒 Button lock indicator

- 🔒 Light on, indicate the buttons are locked. At this moment, press any single button will not work. (No operation in one minute, 🔒 will light on and lock the buttons.)
- Solution: Press and hold both ▲ and ▼ for 5 seconds until the 🔒 light off.







#### C. 🔄 Program mode indicator

- 🔄 Light on, enter program display mode. Use ▲ or ▼ to view all values.
- 🔄 Flash and enter program set mode. Press ▲ or ▼ to adjust values.







**D.  Manu/Confirm button**

- Press  ,  light on, enter program display mode and use  or  to view all values.
- In program display mode, press  ,  flash, enter program set mode, press  or  and adjust values.
- Press  after all program are set, and then the voice “Di ” means all setting are success and return program display mode.

**E.  Manual/Return button**



- Press  in working conditions, it can proceed to next step. (Example: when the outlet water fails to reach the requirement, you can press  to end the service and start an immediate rising. During the process of rising, pressing the  button can end one step in advance and proceed to the next step.)
- Press  in program display mode, and it will return in Service. Press  in program set mode, and it will return program display mode.
- Press  while adjusting the value, then it will return program display mode directly without saving value.

**F. Down  and up **







- In program display mode, press  or  to view all values.
- In program set mode, press  or  to adjust values.
- Press and hold both  and  for 5 seconds to lift the Button Lock status.

**2.2. Basic Setting & Usage**

**A. Parameter specification**







Function	Indicator	Factory Default	Parameter Set Range	Instruction
Time of Day		Random	00:00 ~ 23:59	Set the time of day when use; “: ” flash.
Service Time		1-03D	1-99 D	Regeneration by days.
			1-99 H	Regeneration by hours.
			2	Initate backwash by two times of day.
			3	Initate backwash by three times of day.
			4	Initate backwash by four times of day.
First Time of Day to Initate Backwash		1-12:30	00:00 ~ 23:59	Service mode by multi-times of day to initiate backwash, system will initiate backwash at this time.

## MODEL: 13504

Second Time of Day to Initiate Backwash		2-17:30	00:00 ~ 23:59	Service mode by multi-times of day to initiate backwash, system will initiate backwash at this time.
Third Time of Day to Initiate Backwash		3-21:30	00:00 ~ 23:59	Service mode by multi-times of day to initiate backwash, system will initiate backwash at this time.
Fourth Time of Day to Initiate Backwash		4-02:00	00:00 ~ 23:59	Service mode by multi-times of day to initiate backwash, system will initiate backwash at this time.
Backwash Time	02:00	02:00	00:00 ~ 23:59	Backwash time, “:” light on, only 1-03D mode has this item.
Left Chamber Backwash		20 Min.	0~99	Left chamber backwash time. (Minute)
Right Chamber Backwash		20 Min.	0~99	Right chamber backwash time. (Minute)
Fast Rinse		20 Min.	0~99	Fast rinse time. (Minute)
Output Control Mode	b-01	01	01 or 02	Mode 01: Signal turn on start of regeneration and shut off end of regeneration. (Refer to the Figure 1) Mode 02: Signal turn on start of left or right chamber backwash and backwash water option, and shut off end of them. (Refer to the Figure 5)

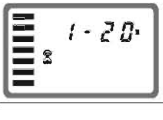
### B. Process Display

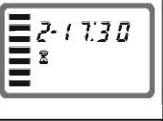
① In service status, each figure show every 10 seconds circularly.

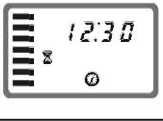
Service Mode	Display				
By Days					
	Left days.	Time of day “:” flash.	Backwash time.		
By Hours					
	Left hours.	Time of day “:” flash			
By Multi-times of Day					
	First time of initiate backwash	Second time of initiate backwash	Third time of initiate backwash	Fourth time of initiate backwash	Time of day “:” flash

## MODEL: 13504

②In backwash status, the strips of left side of display board do not flash. When system process each position, the correspondence figure will light on. Digital area show current time and left times circularly. For example: when right chamber backwash, it shows:





			
Right chamber backwash		Time of day	

Illustration:

- Other positions of backwash, for example, left chamber backwash, fast rinse, each figure shows for 10 seconds circularly: ① Current working position (For example 3-60min.), ② Time of day.
- The display screen will only show “-00-” when the electrical motor is running.
- The time of day figure  flash continuously, such as “12: 12” flash, indicates long outage of power. It reminds to reset the time of day.
- The display will show the error code, such as “-E1-”, when the system is in error.
- Working process: Service → Left Chamber Backwash → Right Chamber Backwash → Fast Rinse.

### C. Usage

After being accomplished installation, parameter setting and trail running, the valve could be put into use. In order to ensure the quality of outlet water can reach the requirement, the user should complete the below woks:

- ① Intiate backwash of system on time to ensure spongy iron media is not compacted.
- ② Regular test whether the dissolved oxygen in outlet water comply with the requirement. In case of dissolved oxygen in outlet water over-standard or inlet outlet pressure drop over-big, press  button to initiate temporary backwash. (It will not affect the original service time.)
- ③ Inlet of deaerator is soft water 【Yd<0.6mg/L】 , the hard water will make spongy iron media be compacted faster.

### 3. Applications

#### 3.1. Flow Chart

##### A. Service status

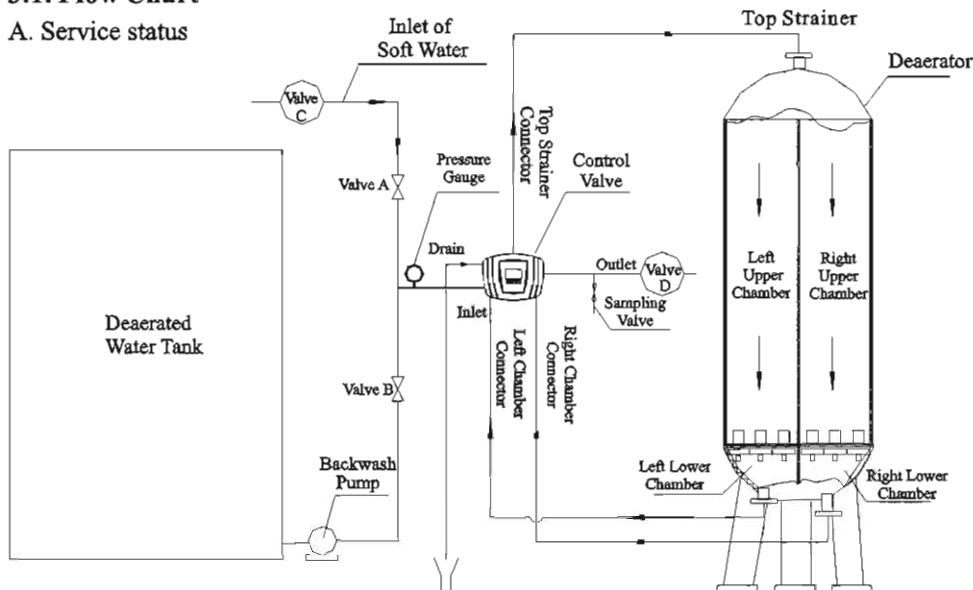

##### B. Left chamber backwash status

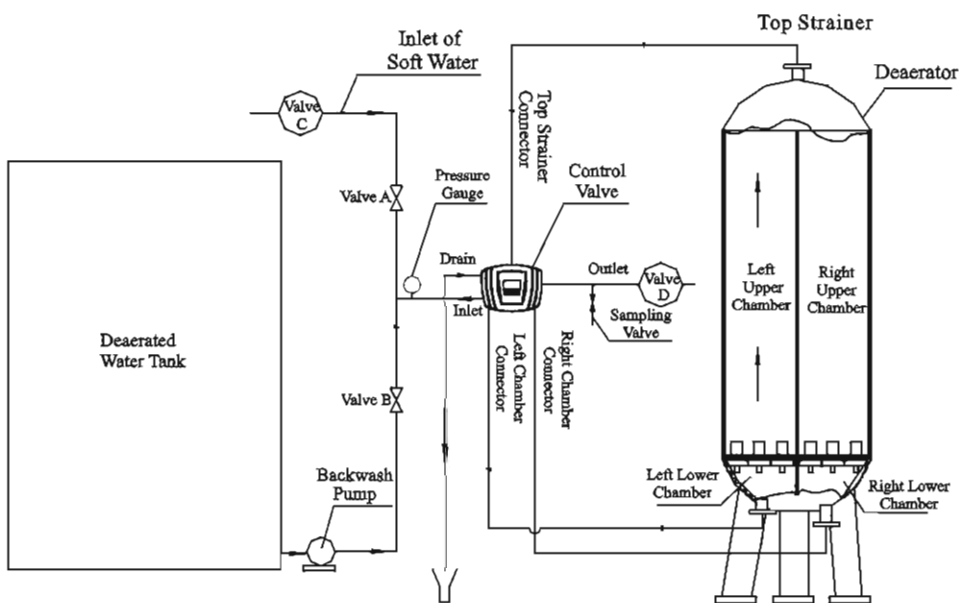

# MODEL: 13504

## C. Right chamber backwash status

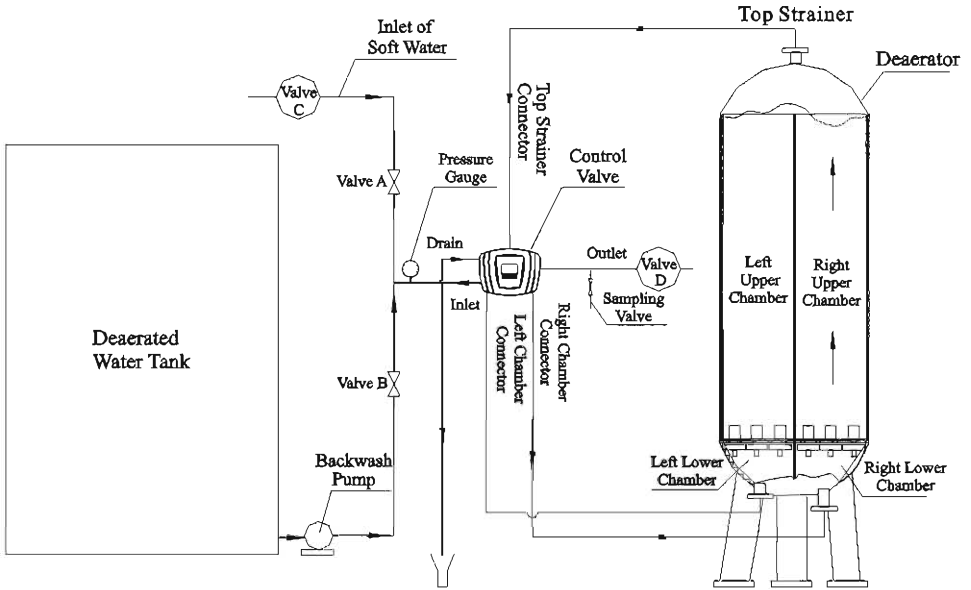

## D. Fast rinse status

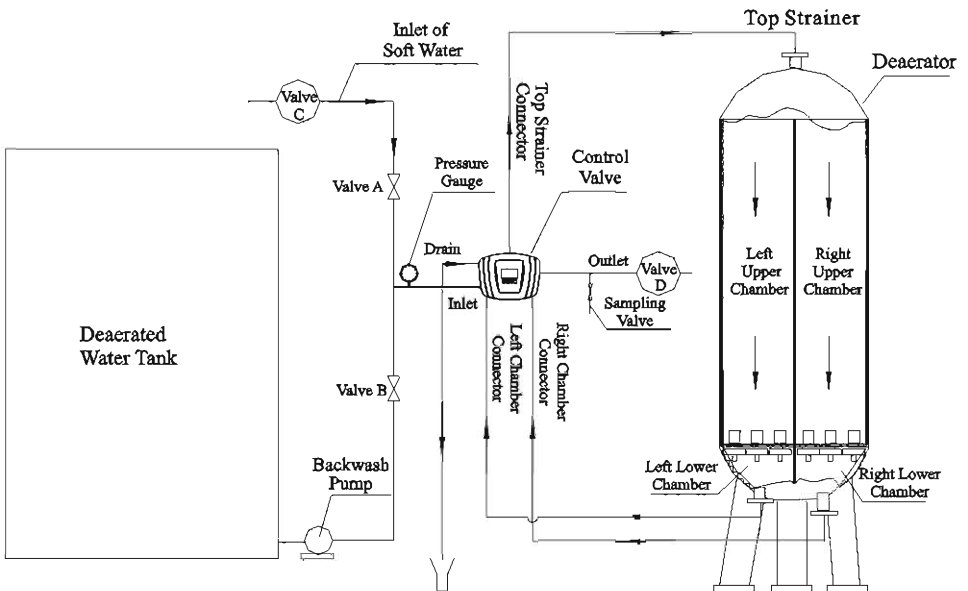

# MODEL: 13504

## 3.2. The Function and Connection of PC Board

Open the front cover of control valve, you will see the main control board and connection port as below:

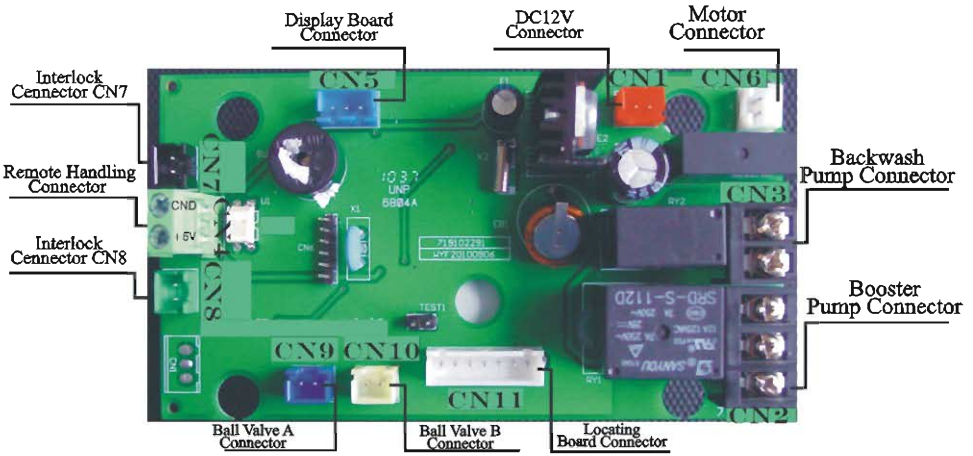

The main functions on main control board:

Function	Application	Explanation
Booster Pump Connector b-01	Inlet booster pump	If inlet pressure is low, use booster pump to increase pressure.
Booster Pump Connector b-01	Outlet solenoid valve	When the valve turns in washing cycle, the solenoid valve is closed.
Backwash booster pump connector	Anaerobic backwash pump	Use anaerobic water for backwash, connect booster pump with anaerobic water tank. Booster pump is open when initiate backwash.
Interlock connector	To ensure only one control valve regeneration or washing in system.	Use in RO pre-treatment, water supply together but regeneration in turn, second grade ion exchange equipment, etc.
Remote handling connector	Receipt signal to make the control rotate to next circle.	It is used for on-line inspection system, PC connection, and realize automatically or remote controlling valve.

### A. Signal Output Connector

#### 1) Control Inlet Booster Pump (Set b-01)

Instruction: If inlet water pressure is less than 0.15MPa, which makes rinse difficult, a booster pump is suggested to be installed on inlet. Control mode b-01. When system in backwash cycle, booster pump is open, the wiring refer to Figure 1. If the booster pump current is bigger than 5A, system need to install a contactor, the wiring refer to Figure 2.



# MODEL: 13504

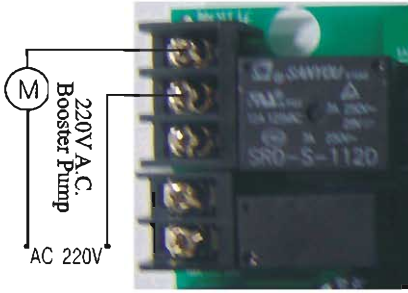

Figure 1

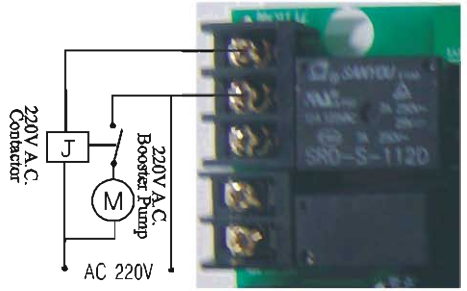

Figure 2

## 2) Solenoid Valve on Outlet (Set b-01)

Instruction: When the valve turns in washing cycle, the solenoid valve is closed, in case water flows from the outlet. The wiring refer to Figure 3.

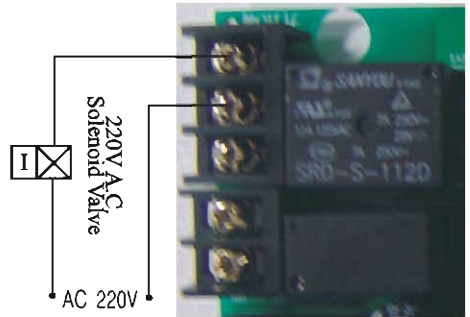

Figure 3

## B. Interlock

Instruction: In the parallel water treatment system, it ensures only one valve in regeneration or washing cycle and (n-1) valves in service, that is, realizing the function of supplying water simultaneously and regenerating individually.

In the series and parallel water treatment system (Second grade  $\text{Na}^+$  Exchanger or RO pre-treatment system), it ensures only one valve in regeneration or washing cycle and there is/are water(s) in service. The wiring refer to Figure 4.

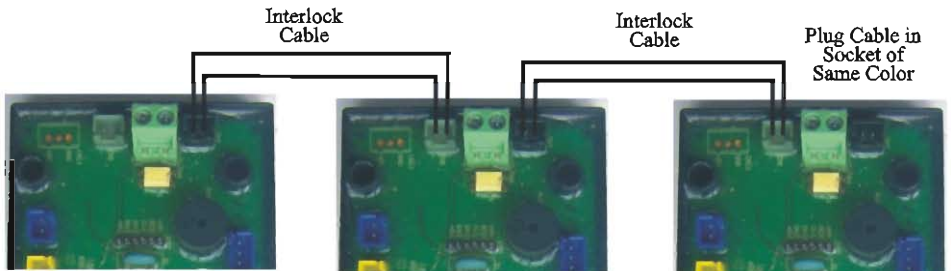

Figure 4

## MODEL: 13504

Note: Use Interlock Cable to connect CN8 to CN7 on next valve in the loop.  
One system with several valves, if interlock cable is disconnected, the system is divided into two individual system.

### C. Backwash Pump Booster Connector (Set b-02)

Instruction: When system need anaerobic water for left or right chamber backwash, connect an AC 220V pump with anaerobic water tank. This pump is supplying anaerobic water inlet pressure. Connect CN3 with pump, the wiring refer to Figure 4. If the pump current is bigger than 5A, system need to install a contactor, the wiring refer to Figure 5.

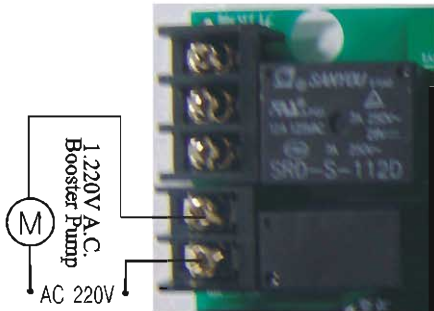

Figure 5

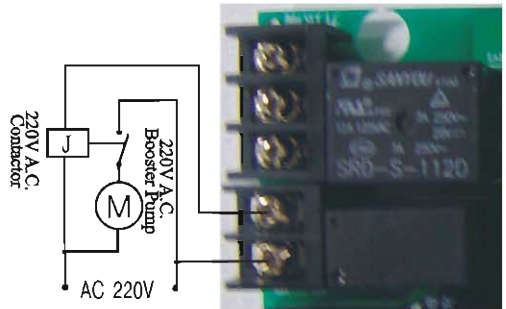

Figure 6

### D. Remote Handling Connector

When valve connect with pressure drop sensor or other online monitor or PLC, when pressure drop reach at backwash set value or PC send a signal to backwash, connect an earth wire of remote handling connector with GND of CN4 on green board. When the controller receives a contact closure from above instruments, backwash begins. The wiring refer to Figure 7:

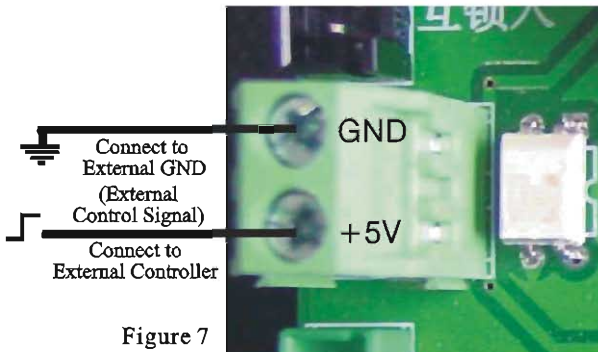

Figure 7

## MODEL: 13504

### 3.3. System Configuration and Flow Rate Curve

#### A. Product Configuration

Product configuration with tank, media weight, backwash rate and pressure.



Tank Size (mm)	Spongy Iron Weight (Kg)	How Rate (t/h)	Backwash Rate (t/h)	Backwash Pressure (Mpa)
φ180 × 1130 【Tank straight line height】	55	0.5	1.0	0.3
φ205 × 1500 【Tank straight line height】	70	0.7	1.5	0.3
φ255 × 1500 【Tank straight line height】	105	1.2	2.5	0.3
φ300 × 1500 【Tank straight line height】	150	1.8	4	0.3
φ350 × 1500 【Tank straight line height】	200	2.5	6	0.3
φ400 × 1500 【Tank straight line height】	270	3.5	8	0.3

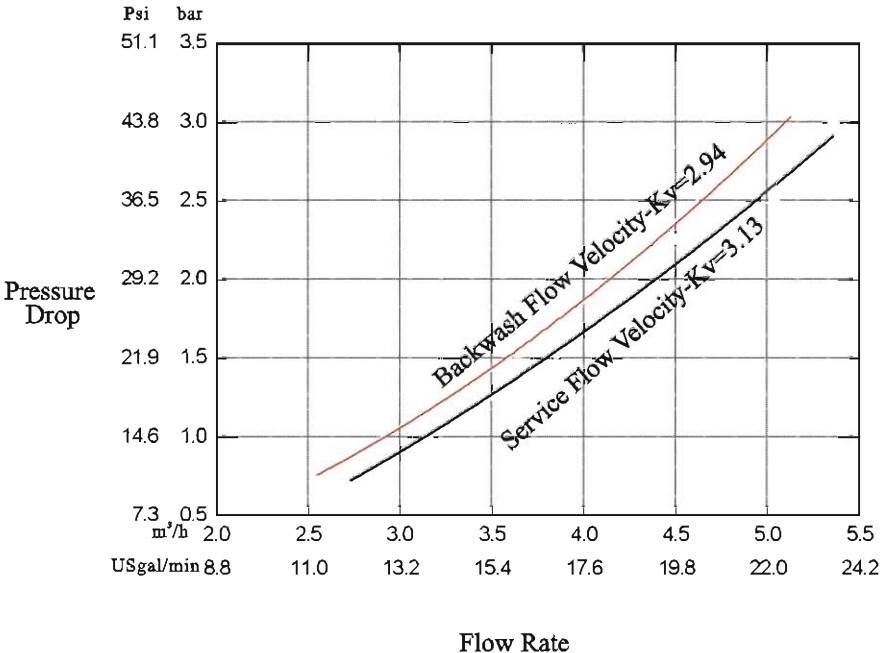

















#### B. Flow Rate Characteristic



### 3.4. Parameter Settlement

#### 3.4.1. Service Unit Set

When system supply with power, all symbols show on board, press and both hold  and  buttons for 2 seconds, enter service unit set mode, follow the process to set. (Press  exit and turn back to service status.)

Items	Process steps	Symbol
Service by Days	<ol style="list-style-type: none"> <li>1. Enter service unit set mode, the default unit is by days, as right symbol.</li> <li>2. Press , save setting service by days, and turn back to service status.</li> </ol>	
Service by Hours	<ol style="list-style-type: none"> <li>1. Enter service unit set mode.</li> <li>2. Press  or , "H" light on, as right symbol.</li> <li>3. Press , save setting service by hours, and turn back to service status.</li> </ol>	
Initate Backwash by Two Times of Day	<ol style="list-style-type: none"> <li>1. Enter service unit set mode.</li> <li>2. Press  or , "2" light on, as right symbol.</li> <li>3. Press , save setting initiate backwash by two times of day, and turn back to service status.</li> </ol>	
Initate Backwash by Three Times of Day	<ol style="list-style-type: none"> <li>1. Enter service unit set mode.</li> <li>2. Press  or , "3" light on, as right symbol.</li> <li>3. Press , save setting initiate backwash by three times of day, and turn back to service status.</li> </ol>	
Initate Backwash by Four Times of Day	<ol style="list-style-type: none"> <li>1. Enter service unit set mode.</li> <li>2. Press  or , "4" light on, as right symbol.</li> <li>3. Press , save setting initiate backwash by four times of day, and turn back to service status.</li> </ol>	

### 3.4.2. Parameter Enquiry

When light on, press and hold both and for 5 seconds to lift the button lock status; then press and light on, enter to program display mode; press or to view each value according to below process. (Press exit and turn back to service status)

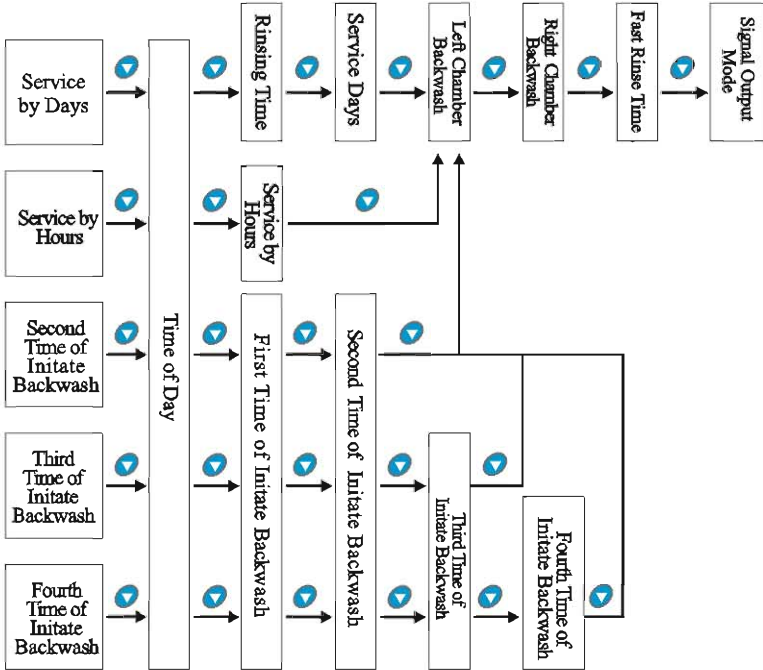

















































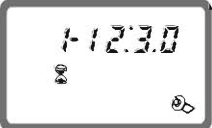

### 3.4.3. Parameter Setting

In program display mode, press and enter into program set mode. Press or to adjust the value.







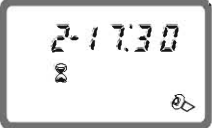













































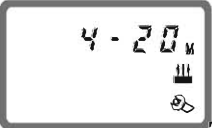

### 3.4.4. The Steps of Parameter Setting

Items	Process steps	Symbol
Time of Day	<p>When time of day  continuously flash, it reminds to reset;</p> <ol style="list-style-type: none"> <li>1. Press  to enter into program display mode; both  and  symbol light on, “:” flash;</li> <li>2. Press , both  and hour value flash, through  or  to adjust the hour value;</li> <li>3. Press  again, both  and hour value flash, through  or  to adjust the minute value;</li> <li>4. Press  and hear a sound “Di” then finish adjustment, press  to turn back.</li> </ol>	

## MODEL: 13504

<p>Backwash Time</p>	<ol style="list-style-type: none"> <li>1. In backwash time display status. Press  and enter into program set mode.  and 02 flash;</li> <li>2. Press  or  to adjust the backwash time;</li> <li>3. Press ,  and “00” flash;</li> <li>4. Press  or  to adjust the backwash time (Minute);</li> <li>5. Press  and hear a sound “Di”, then finish adjustment, press  to turn back.</li> </ol>	
<p>Service by Days</p>	<ol style="list-style-type: none"> <li>1. In service by days mode and service by days display status, it shows  and 1-03D. Press  and enter into program set mode.  and 03 flash;</li> <li>2. Press  or  to adjust the service by days;</li> <li>3. Press  and hear a sound “Di”, then finish adjustment, press  to turn back.</li> </ol>	
<p>Service by Hours</p>	<ol style="list-style-type: none"> <li>1. In service by days mode and service by days display status, it shows  and 1-20H. Press  and enter into program set mode.  and 20 flash;</li> <li>2. Press  or  to adjust the service by hours (H);</li> <li>3. Press  and hear a sound “Di”, then finish adjustment, press  to turn back.</li> </ol>	
<p>First Time of Initiate Backwash</p>	<ol style="list-style-type: none"> <li>1. In multi-times of initiate backwash mode and first time of initiate backwash display status, it shows  and 1-12:30.</li> <li>2. Press  and enter into program set mode.  and 12 flash. Press  or  to adjust the hour value.</li> <li>3. Press  and enter into program set mode.  and minute value flash. Press  or  to adjust the minute value.</li> <li>4. Press  and hear a sound “Di”, then finish adjustment, press  to turn back.</li> </ol>	
<p>Second Time of Initiate Backwash</p>	<ol style="list-style-type: none"> <li>1. In multi-times of initiate backwash mode and second time of initiate backwash display status, it shows  and 2-17:30.</li> <li>2. Press  and enter into program set mode.  and 17 flash. Press  or  to adjust the hour value</li> <li>3. Press  and enter into program set mode.  and minute value flash. Press  or  to adjust the minute value.</li> <li>4. Press  and hear a sound “Di”, then finish adjustment, press  to turn back.</li> </ol>	



## MODEL: 13504



<p>Third Time of Initiate Back-wash</p>	<ol style="list-style-type: none"> <li>1. In multi-times of initiate backwash mode and third time of initiate backwash display status, it shows  and 3-21:30.</li> <li>2. Press  and enter into program set mode.  and 21 flash. Press  or  to adjust the hour value.</li> <li>3. Press  and enter into program set mode.  and minute value flash. Press  or  to adjust the minute value.</li> <li>4. Press  and hear a sound “Di”, then finish adjustment, press  to turn back.</li> </ol>	
<p>Fourth Time of Initiate Back-wash</p>	<ol style="list-style-type: none"> <li>1. In multi-times of initiate backwash mode and fourth time of initiate backwash display status, it shows  and 4-02:00.</li> <li>2. Press  and enter into program set mode.  and 02 flash. Press  or  to adjust the hour value.</li> <li>3. Press  and enter into program set mode.  and minute value flash. Press  or  to adjust the minute value.</li> <li>4. Press  and hear a sound “Di”, then finish adjustment, press  to turn back.</li> </ol>	
<p>Left Chamber Back-wash Time</p>	<ol style="list-style-type: none"> <li>1. In left chamber backwash time display status, it shows  and 2-20. Press  and enter into program set mode  and 20 flash;</li> <li>2. Press  or  to adjust the backwash time (Minute);</li> <li>3. Press  and hear a sound “Di”, then finish adjustment, press  to turn back.</li> </ol>	
<p>Right Chamber Back-wash Time</p>	<ol style="list-style-type: none"> <li>1. In right chamber backwash time display status, it shows  and 3-20. Press  and enter into program set mode.  and 20 flash;</li> <li>2. Press  or  to adjust the backwash time (Minute);</li> <li>3. Press  and hear a sound “Di”, then finish adjustment, press  to turn back.</li> </ol>	
<p>Fast Rinse Time</p>	<ol style="list-style-type: none"> <li>1. In fast rinse time display status, it shows  and 4-20. Press  and enter into program set mode.  and 20 flash;</li> <li>2. Press  or  to adjust the fast rinse time (Minute);</li> <li>3. Press  and hear a sound “Di”, then finish adjustment, press  to turn back.</li> </ol>	
<p>Signal Output Mode</p>	<ol style="list-style-type: none"> <li>1. In signal output mode display status, it shows  b-01. Press  and enter into program set mode. and 01 flash;</li> <li>2. Press  or  to adjust the b-02;</li> <li>3. Press  and hear a sound “Di”, then finish adjustment, press  to turn back.</li> </ol>	



### 3.5. Trial Running



After installing the pipeline of multi-functional flow control valve on, as well as setting up the relevant parameter, please conduct the trial running as follows:

A. Switch on power. Set signal output mode to b-01.

B. Press  and go in the Left Chamber Backwash position; when  light on, slowly open the manual valve C to 1/4 position, making the softened water flow into the deaerator tank; you can hear the sound of air-out from the drain pipeline. After all air is out of pipeline, then open inlet valve C completely and clean the foreign materials in left chamber until the outlet water is clean. It will take 10 minutes to finish the whole process.

C. Press  to finish Left Chamber Backwash position, turning the position to Right Chamber Backwash position.  light on, clean the foreign materials in right chamber until the outlet water is clean. It will take 10 minutes to finish the whole process.

D. Press  to finish Right Chamber Backwash position, turning the position to Fast Rinse position.  light on, fast rinse for 10 minutes. Take our some outlet water for testing: if the water dissolved oxygen reach the requirement, then go to the next step.

E. Press  to finish Fast Rinse position, making the control valve return to Service Status;  light on and start to running.

#### Illustration:

- When the control valve enter into the backwash status, all program can be finished automatically according to the setting time; if you want one of steps terminated early, you can press .
- After changing media, please empty air in the spongy iron according to the above Step 2.
- In the process of trial running, please check the water situation in all position, ensuring there are no spongy iron leakage.
- The time for Left Chamber Backwash, Right Chamber Backwash and Fast Rinse position can be set and executed according to the calculation in the formula or suggestions from the control valve suppliers.



## MODEL: 13504

### 3.6. Trouble-Shooting

#### A. Control Valve Fault

Problem	Cause	Correction
1. Deaerator fails to regenerate.	A. Electrical service to unit has been interrupted. B. Regeneration cycles set incorrect. C. Controller is defective.	A. Assure permanent electrical service (Check fuse, plug or switch). B. Reset regeneration cycles. C. Replace controller.
2. Deaerator supply aerobic water.	A. Spongy iron failure. B. Internal valve leak.	A. Replace spongy iron. B. Change valve body.
3. No water flow out from outlet in service.	A. Electronic ball valve A broken or cable damaged which result in ball valve can't open.	A. Check and replace electronic ball valve.
4. Pressure lost	A. Iron in the water supply pipe. B. Iron mass in the deaerator.	A. Clean the water supply pipe. B. Clean valve and spongy iron, increase frequency of backwash.
5. Loss of spongy iron through drain line.	A. Air in water system. B. Strainer broken.	A. Assure that well system has proper air eliminator control. B. Replace new strainer.
6. Control cycle continuously.	A. Locating signal wiring breakdown. B. Controller is faulty. C. Foreign material stuck the driving gear.	A. Check and connect locating signal wiring. B. Replace controller. C. Take out foreign material.
7. Drain flows continuously.	A. Internal valve leak. B. When electricity fails to supply, valve stops on backwash or fast rinse position.	A. Check and repair valve body or replace it. B. Restart unit when electricity supply.

MODEL: 13504

**B. Controller Fault**

Problem	Cause	Correction
1. All indicators display on front panel.	A. Wiring of display board with control board fails to work. B. Control board is faulty. C. Transformer damaged. D. Voltage is not stable.	A. Check and replace the wiring. B. Replace control board. C. Check and replace transformer. D. Check and adjust electrical service.
2. No display on front panel.	A. Wiring of display board with control board fails to work. B. Display board damaged. C. Control board damaged. D. Electricity is interrupted.	A. Check and replace wiring. B. Replace display board. C. Replace control board. D. Check electricity.
3. E1 Flash	A. Wiring of locating board with control board fails to work. B. Locating board damaged. C. Mechanical driver fails. D. Faulty control board. E. Wiring of motor with control board is fault. F. Motor damaged.	A. Replace wiring. B. Replace locating board. C. Check and repair mechanical part. D. Replace control board. E. Replace wiring. F. Replace motor.
4. E2 Flash	A. Hall component on locating board damaged. B. Wiring of locating board with control board fails to work. C. Control board is faulty.	A. Replace locating board. B. Replace wiring. C. Replace control board.
5. E3 or E4 Flash	A. Control board is faulty.	A. Replace control board.

# MODEL: 13504

## 7、組件及零部件編號

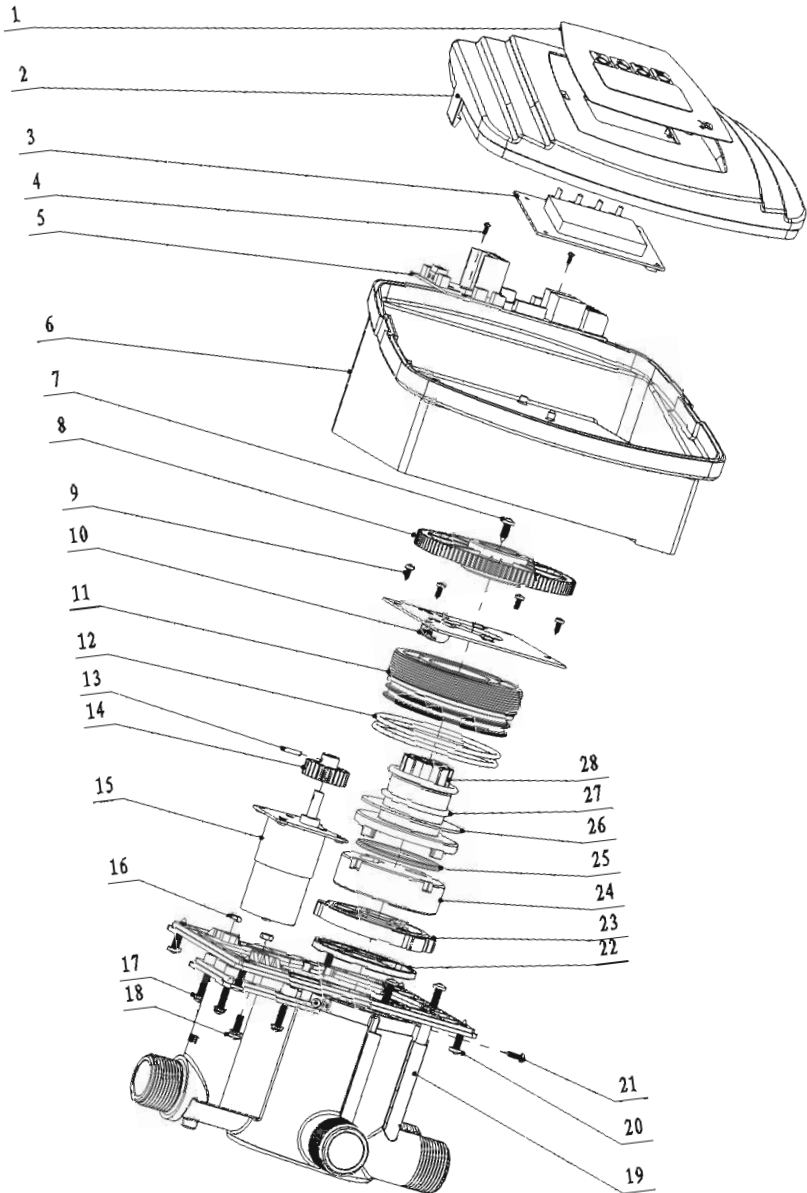

## MODEL: 13504

### 13504 Valve Body Components

Item No.	Description	Part Number	Quantity	Item No.	Description	Part Number	Quantity
1	Label	8865001	1	16	Hexagonal Nut	8940002	2
2	Front Cover	8300002	1	17	Screws, Cross	8902006	4
3	Display Board	6381003	1	18	Screws, Cross	8902005	2
4	Screw, Cross	8909004	2	19	Valve Body	8022010	1
5	Control Board	6382044	1	20	Screw, Cross	8909003	7
6	Dust Cover	8005002	1	21	Screw, Cross	8909008	3
7	Screw, Cross	8909013	1	22	Seal Ring	8370009	1
8	Big Gear, Driven	5241002	1	23	Fixed Disk	8469006	1
9	Screw, Cross	8909008	4	24	Moving Disk	8459006	1
10	Locating Board	6380024	1	25	Moving Seal Ring	8370001	1
11	Fitting Nut	8092004	1	26	Anti-friction Washer	8216004	1
12	O-ring	8378128	2	27	O-ring	8378184	2
13	Pin	8993001	1	28	Shaft	8258004	1
14	Small Gear, Motor	8241003	1	29	Wire for Locating Board	5511002	1
15	Motor	6158022	1	30	Wire for Display Board	5512001	1

## 4. Warranty Card

Dear client:

This warranty card is the guarantee proof of RUNXIN brand multi-functional flow control valve. It is kept by client self. You could get the after-sales services from the supplier which is appointed by RUNXIN manufacturer. Please keep it properly. It couldn't be retrieved if lost. It couldn't be repaired free of charge under the below conditions:

1. Guarantee period expired.(One year);
2. Damage resulting from using, maintenance, and keeping that are not in accordance with the instruction;
3. Damage resulting from repairing not by the appointed maintenance personnel;
4. Content in guarantee proof is unconfirmed with the label on the real good or be altered;
5. Damage resulting from force majeure.

Product Name	 Multi-functional Flow Control Valve for Water Treatment Systems			
Model		Code of Valve Body		
Purchase Company Name		Tel/Cel.		
Problem				
Solution				
Date of Repairing		Date of Accomplishment		Maintenance Man Signature

When product need warranty service, please fill in the below content and send this card together with the product to the appointed suppliers or Runxin company.

End-user Company Name		Tel/Cel.	
Purchase Company Name		Tel/Cel.	
Model		Code of Valve Body	
Tank Size $\phi$ ×		Media Model L	Media Weight Kg
Water Source: Ground-water <input type="checkbox"/> Tap Water <input type="checkbox"/>		Inlet Pressure Mpa	Water Treatment Capacity
Left Chamber Backwash Time Min.		Right Chamber Backwash Time Min.	Fast Rinse Time Min.
Problem Description			



---

**WENZHOU RUNXIN MANUFACTURING MACHINE CO.,LTD**

ADD: Jinger Road, Shatou Group, Linjiang, Lucheng District, Wenzhou, Zhejiang, China

Tel: +86-577-88635628 88630038 Fax: +86-0577-88633258

Http://www.run-xin.com Email:sales@run-xin.com